

LAG-2800

LAG Equipment proudly presents their latest refractory tear-out machine designed for safety and innovation.



UNDERCARRIAGE

- High pressure/low flow motor and high torque hub effortlessly turn machine
- Narrower undercarriage track profile allow for better maneuverability
- Undercarriage d-rings allow for safe tie-down for transportation

FUEL TANK/HYDRAULIC RESERVOIR

- No-spill fill
- Bottom fill eliminates fall protection
- Certified pressure tested

CONTROL SYSTEM

- Joystick controlled radio system with optional layouts (SAE, NON-SAE, or Gradall)
- No tethered control pendant

ELECTRICAL

- Simplified wiring layout
- Safety perimeter lighting
- Complete LED lighting (spot, flood, strobe)

OPTIONAL EQUIPMENT AVAILABLE:

- Personnel detection system (utilizing six shielded cameras to detect personnel within working range of machine)
- Tag proximity detection system (utilizing ultra high band frequency operator equipped tags to detect the operator within working range of machine)
- Fire suppression system

DECK

- Reduced structural fatigue through FEA analysis
- Better stability with machine's center of mass over undercarriage
- Lifting balance centered to machine
- Diesel engine optimized for superior hydraulic system (limited regen due to engine operating at peak performance)
- All major deck hydraulic components are shielded by enclosures
- High pressure/low flow proportional hydraulic system
- Fewer hydraulic components allow for a simplified, yet powerful system
- Active kidney loop hydraulic cooling system
- Integrated counterbalance valves on hoist cylinders

LAG Equipment
Company owned by Louis A. Grant, Jr.
4300 Commerce Circle, Trafford, PA 15085
412-798-6505 sales@lagequipment.com



LAG-2800

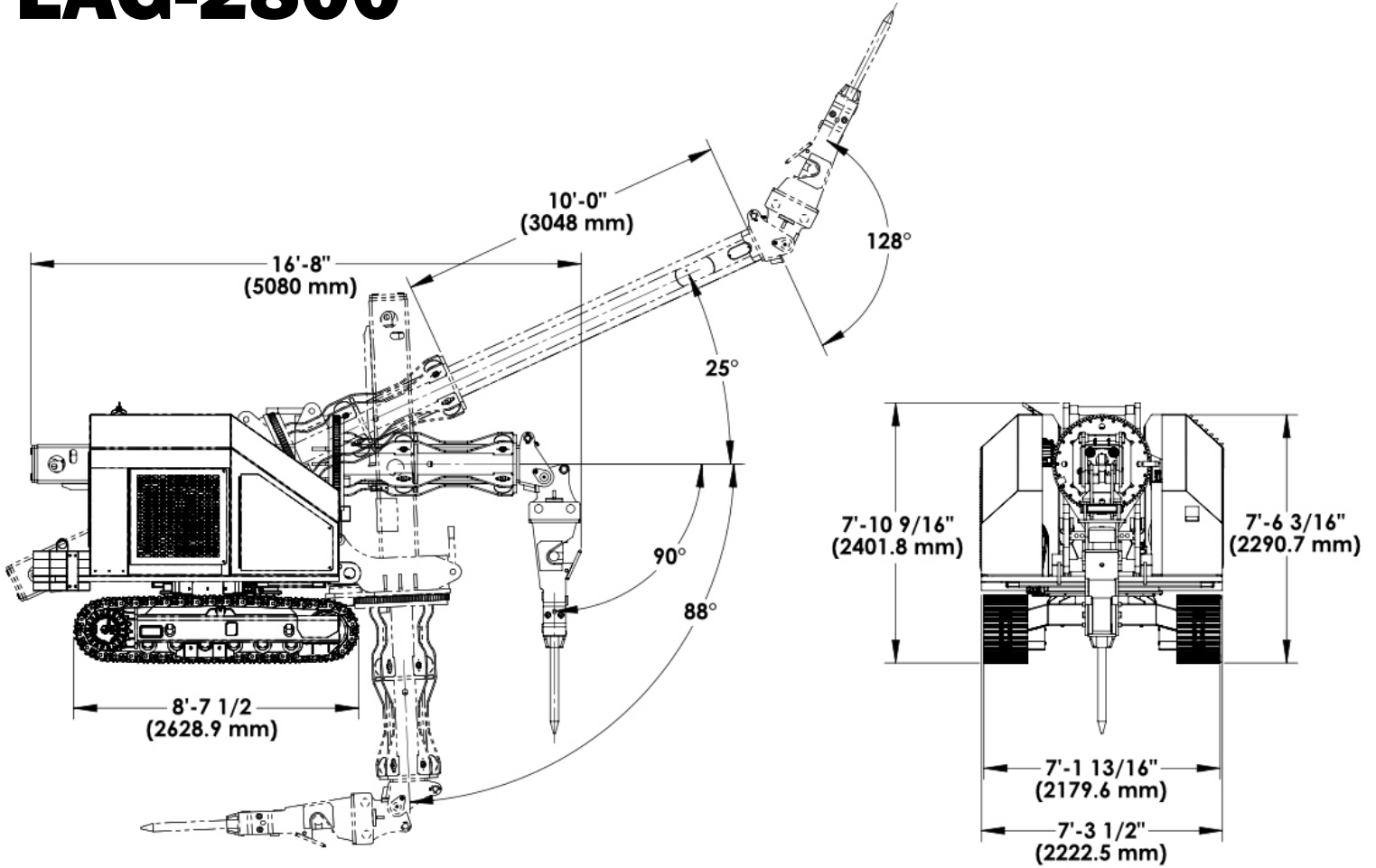

LAG Equipment
Company owned by Louis A. Grant, Jr.
4300 Commerce Circle, Trafford, PA 15085
412-798-6505 sales@lagequipment.com

